

Grout Pumps (High Pressure)

Colcrete Eurodrill manufactures and supplies the comprehensive range of Colcrete high pressure ram and piston pumps, widely used for the pumping of cementitious grouts bentonite and other slurries in the construction, tunnelling and mining industries.

The Mocol range of double acting piston pumps are suitable for handling a wide variety of products including neat cement, PFA cement and sand cement grouts. All except the AL are Electro-hydraulic featuring variable displacement hydraulic pumps with power limiting controls. This provides accurate speed control without heat generation together with a full range of pressures from a single piston size, common to all the pumps. The Mocol HL and HS pumps can be supplied with a variety of power packs to provide the most economic solution to the required combination of output and pressure. The most common ones are shown in the table below.

The Minicol range of ram pumps cover the lower pumping rates and offer great flexibility in that they can be supplied for either vertical or horizontal installation and are available as "single acting", "double acting" or "twin" pumps. They are designed for reliable operation and easy maintenance, having quick release valve assemblies. They are suitable for use with most grouts, bentonites and other slurries.

The hand powered Minicol 160H completes the range, being a versatile single acting ram pump, suitable for a wide variety of products including neat cement, PFA cement and fine sand cement grouts.

MODEL	DESCRIPTION	MAX OUTPUT M3/Hr	MAX PRESS (BARS)	DRIVE OPTIONS	
				ELECTR (kW)	AIR (M3/MIN)
MOCOL HL (22kW)	GROUT PUMP (D/acting piston)	12	100	22	
MOCOL HL (15kW)	GROUT PUMP (D/acting piston)	9.0	100	15	
MOCOL HS (11kW)	GROUT PUMP (D/acting piston)	7.8	90	11	
MOCOL HS (7.5kW)	GROUT PUMP (D/acting piston)	6.0	100	7.5	
MOCOL AL (Air)	GROUT PUMP (D/acting piston)	10.0	50	-	11.3
MAXICOL	GROUT PUMP (Twin piston)	9.6/4.8	50/100	15	
MIDICOL 180DHP	GROUT PUMP (D/acting ram)	6.0	100	11	
MINICOL 160DHP	GROUT PUMP (D/acting ram)	4.5	100	11	
MINICOL 160T	GROUT PUMP (Twin ram)	4.5	33	5.5	
MINICOL 135T	GROUT PUMP (Twin ram)	1.5	100	5.5	
MINICOL 160SHP	GROUT PUMP (S/acting ram)	2.2	100	5.5	5.5
MINICOL 160H	GROUT PUMP (S/acting ram)	1.5	10	-	-

Atlantic Drill & Equipment Company, Inc.

P. O. Box 488 - 273 Lakeview Drive, Woodstock, Virginia 22664 Toll Free: 866-459-5309/ Tel: 540-459-5309/ Fax: 540-459-3071

www.AtlanticDrill.com

S:\Sales\BROCHURE\160dhp\CC160DHP12VDC BROCHURE.doc

CC160DHP12VDC



Atlantic Drill & Equipment Company, Inc.

P. O. Box 488 - 273 Lakeview Drive, Woodstock, Virginia 22664 Toll Free: 866-459-5309/ Tel: 540-459-5309/ Fax: 540-459-3071

www.AtlanticDrill.com

S:\Sales\BROCHURE\160dhp\CC160DHP12VDC BROCHURE.doc

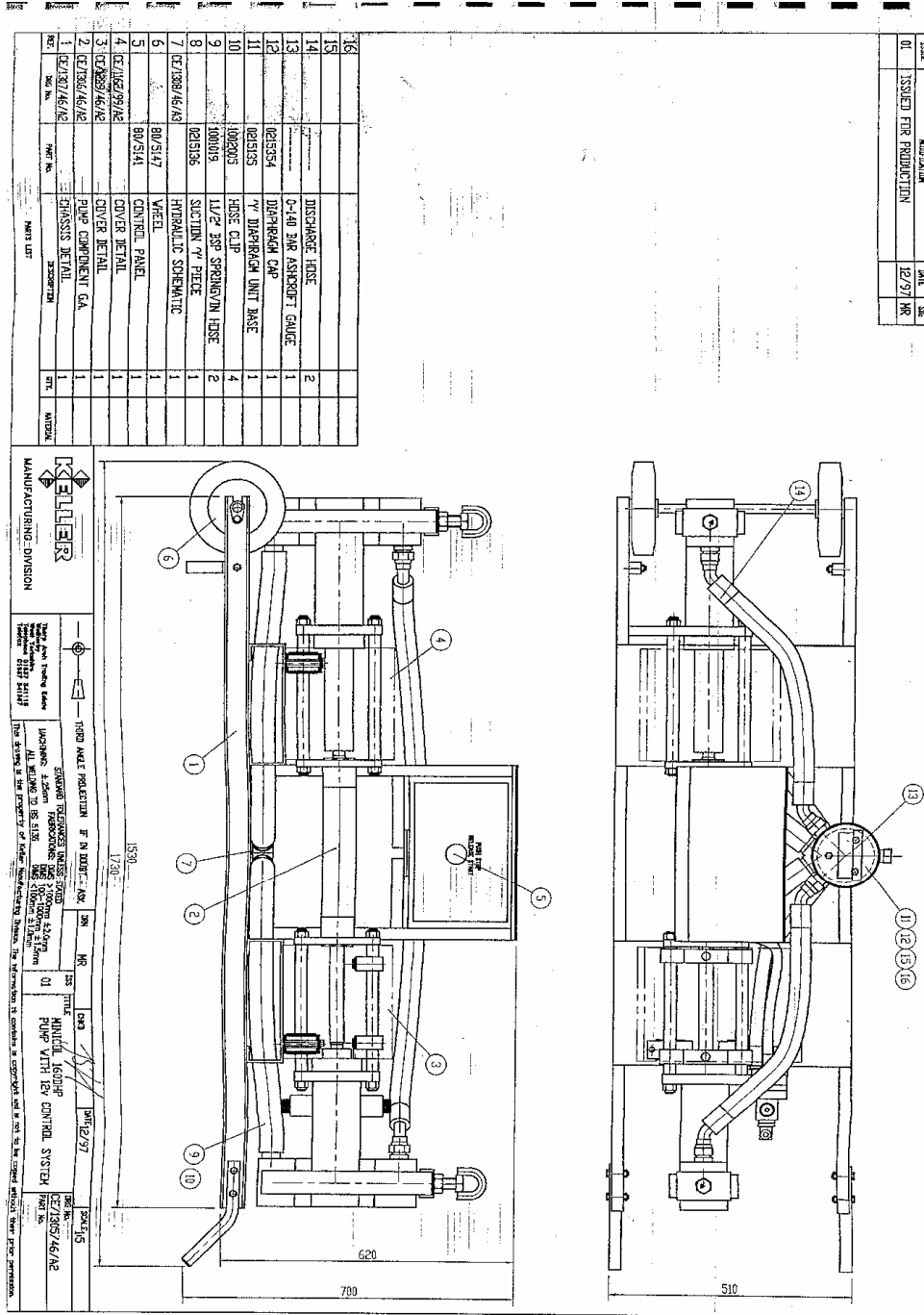

Atlantic Drill & Equipment Company, Inc.

P. O. Box 488 - 273 Lakeview Drive, Woodstock, Virginia 22664 Toll Free: 866-459-5309/ Tel: 540-459-5309/ Fax: 540-459-3071

www.AtlanticDrill.com

S:\Sales\BROCHURE\160dhp\CC160DHP12VDC BROCHURE.doc

